



Lift and Escalator Industry Association

33-34 Devonshire Street London WIN 1RF
Tel: 0171 935 3013 Fax: 0171 935 3321

To: All Members
c.c. The Quality & Technical Committee (Code No: 110)

12 September 1997

Dear Sir

E A Foulds Ltd - Flameproof Lock

Please find enclosed a letter from the above company dated 10th September and attachments which I trust will be found to be self explanatory.

Please be guided accordingly.

Yours faithfully

A handwritten signature in black ink, appearing to read 'D M Fazakerley', written over a horizontal line.

D M Fazakerley
Director

Enc.



AF/SD

10 September 1997

Mr D M Fazakerley
Director
LEIA
33-34 Devonshire Street
LONDON W1N 1RF

Dear Sir

An incident has occurred where part of the internal assembly of a Foulds Flameproof lock became loose causing both the pre-lock and gate beak circuits to remain made. This allowed the landing door to be opened when the lift was not there. The lock was manufactured between January 1996 and August 1997. The locks lie in the number sequence 924 to 986.

These locks can be easily identified from those previously manufactured by the difference in shape.

This problem was caused when the limit switches within the lock became loose. To overcome this problem:

- (1) Two angles, labelled (A), have been added to the contact box.
- (2) The fixing screws, labelled (B), have been securely fastened to the box.

This prevents the switches from moving.

Due to the safety implications of this failure would all persons who have received any of these locks please contact E A Foulds immediately so that the necessary modifications can be carried out promptly.

Yours faithfully
E A FOULDS LIMITED



A Foulds
Project Director

Copy to: Hammond & Champness Limited/Mr R Berry(Manchester
/Mr R Patrickson(Leeds)

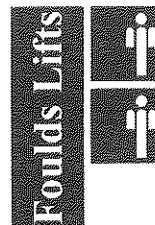

E.A. FOULDS LIMITED
LIFTS DIVISION
ALBERT WORKS
COLNE
LANCASHIRE BB8 9AE
TELEPHONE: 01282 861500
FAX: 01282 869655

SALES OFFICES:

WALES:
CARDIFF
TELEPHONE: 01222 231602

LONDON AND SOUTH EAST:
SOUTH CROYDON
TELEPHONE: 0181 684 6611

SCOTLAND:
ROTHERSAY
TELEPHONE: 01700 504555

IRELAND:
DUBLIN
TELEPHONE: (1) 6719466

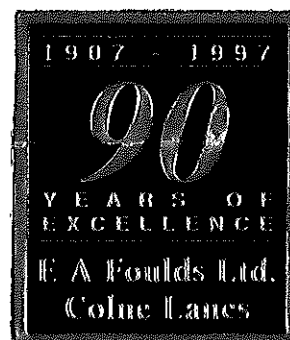

LEIA
LIFT AND ESCALATOR
INDUSTRY ASSOCIATION



LOCK WITH POTENTIAL PROBLEM

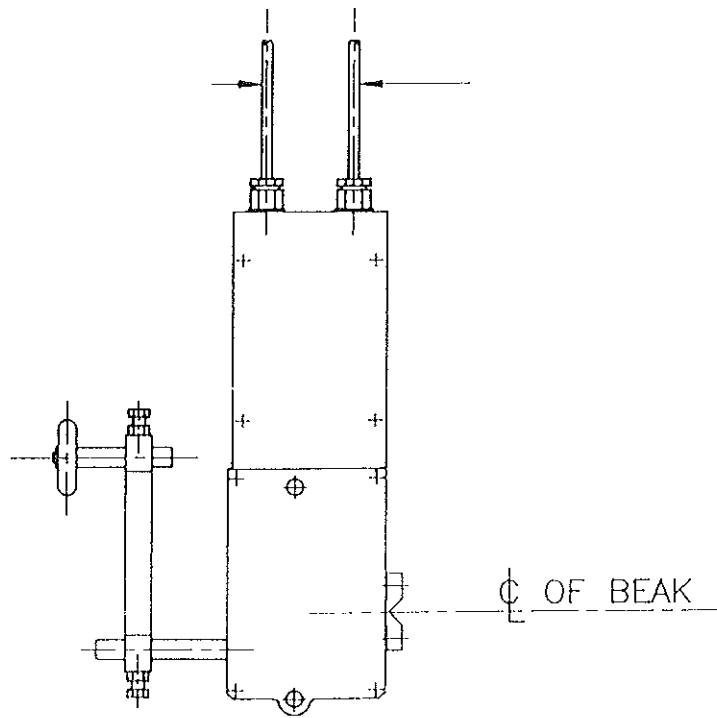

LOCKS WITHOUT PROBLEM

