

National Association of Lift Makers

NALM

33/34 Devonshire Street London W1N 1RF

Director D M Fazakerley

telephone: 071-935 3013

fax: 071-935 3321

To: All Members
cc: The Quality and Technical Committee (Code No 1454)

29 November 1991

Dear Sir,

Hammond & Champness Type DC 68 Landing Door Interlock Equipment

To avoid abuse and render secure the above mentioned type of landing door lock the Company recommends a lock beak setting procedure as illustrated in the enclosed drawings. It is stated:

'Once the beak movement has been adjusted, the position is set. Inspection should not be necessary over and above normal service requirements, it is recommended that this type of lock is inspected at six monthly intervals'.

Will members please be guided accordingly.

Yours faithfully,



D M Fazakerley
Director

DC 68 LANDING INTERLOCK EQUIPMENT

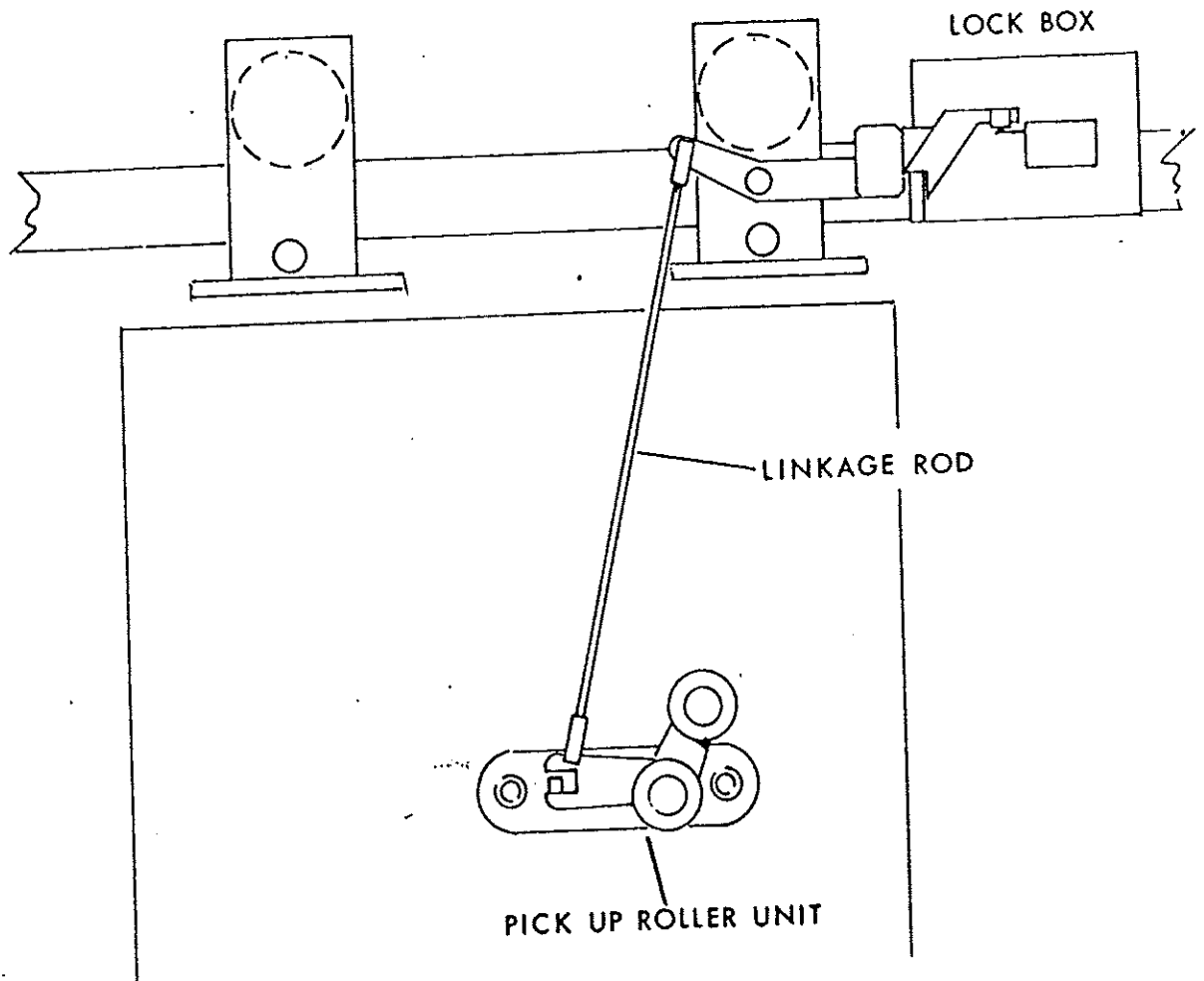

FIG.1

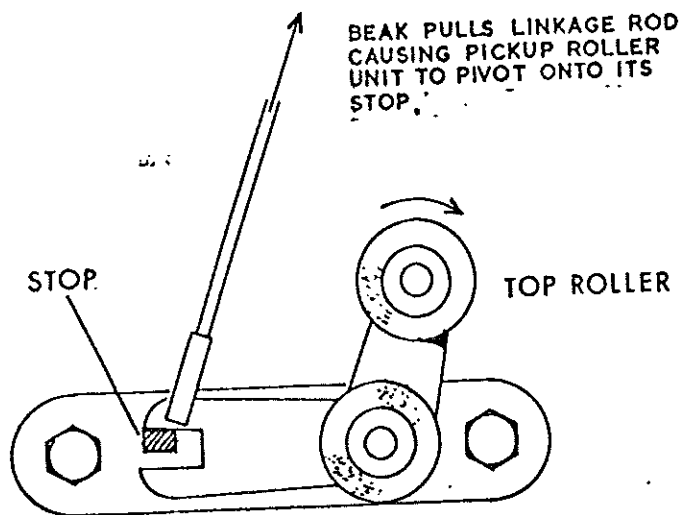
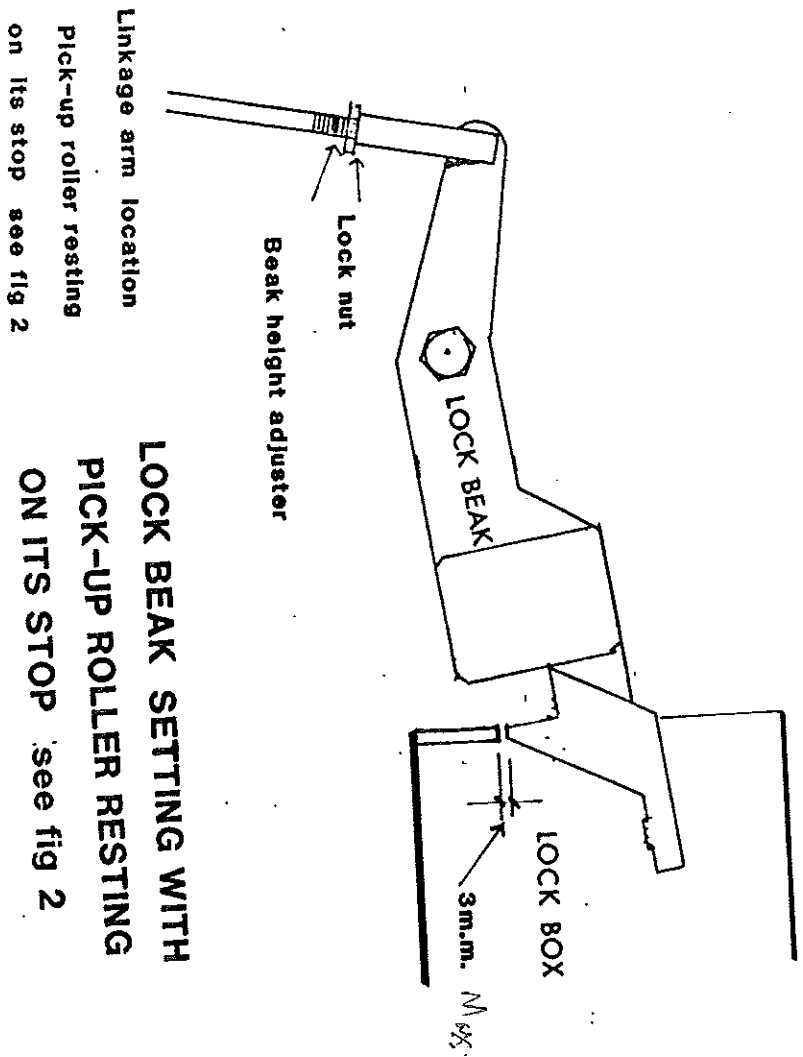

FIG 2



**LOCK BEAK SETTING WITH
PICK-UP ROLLER RESTING
ON ITS STOP see fig 2**

Fig 3

note!
ensure that the lock box cover
fixing screw does not prevent
full beak penetration

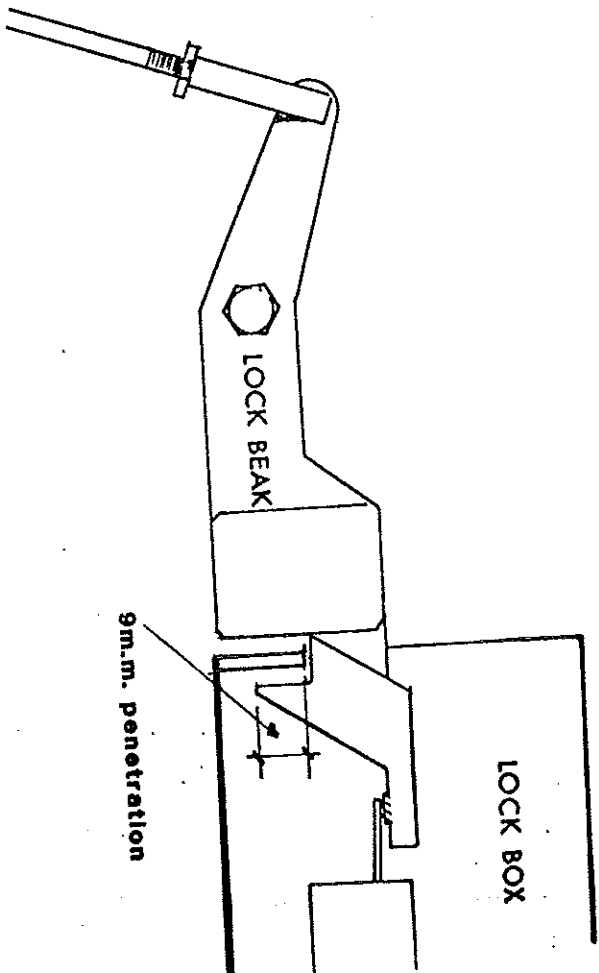

LOCK BEAK IN LOCKED POSITION

Fig 4