

National Association of Lift Makers

33/34 Devonshire Street London W1N 1RF

Director D M Fazakerley

NALM

telephone: 071-935 3013

fax: 071-935 3321

To: All Members
cc: The Technical Committee (1445)

11th October 1991

Dear Sir,

Dewhurst Electromagnetic Brakes

Please find enclosed Technical Bulletin L.130 which the above company has asked we circulate to all members.

Please be guided accordingly.

Yours sincerely,



D M Fazakerley
Director

FIGURE 1 - COMPRESSION SPRING ASSEMBLY

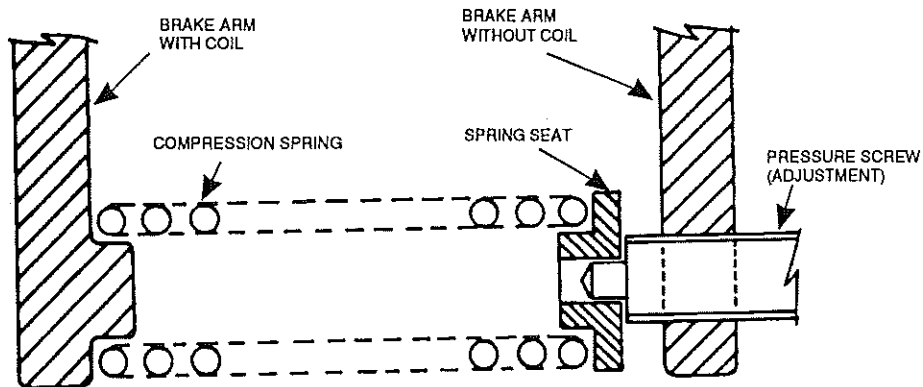

DETAILS OF CORRECT METHOD OF COMPRESSION SPRING ASSEMBLY

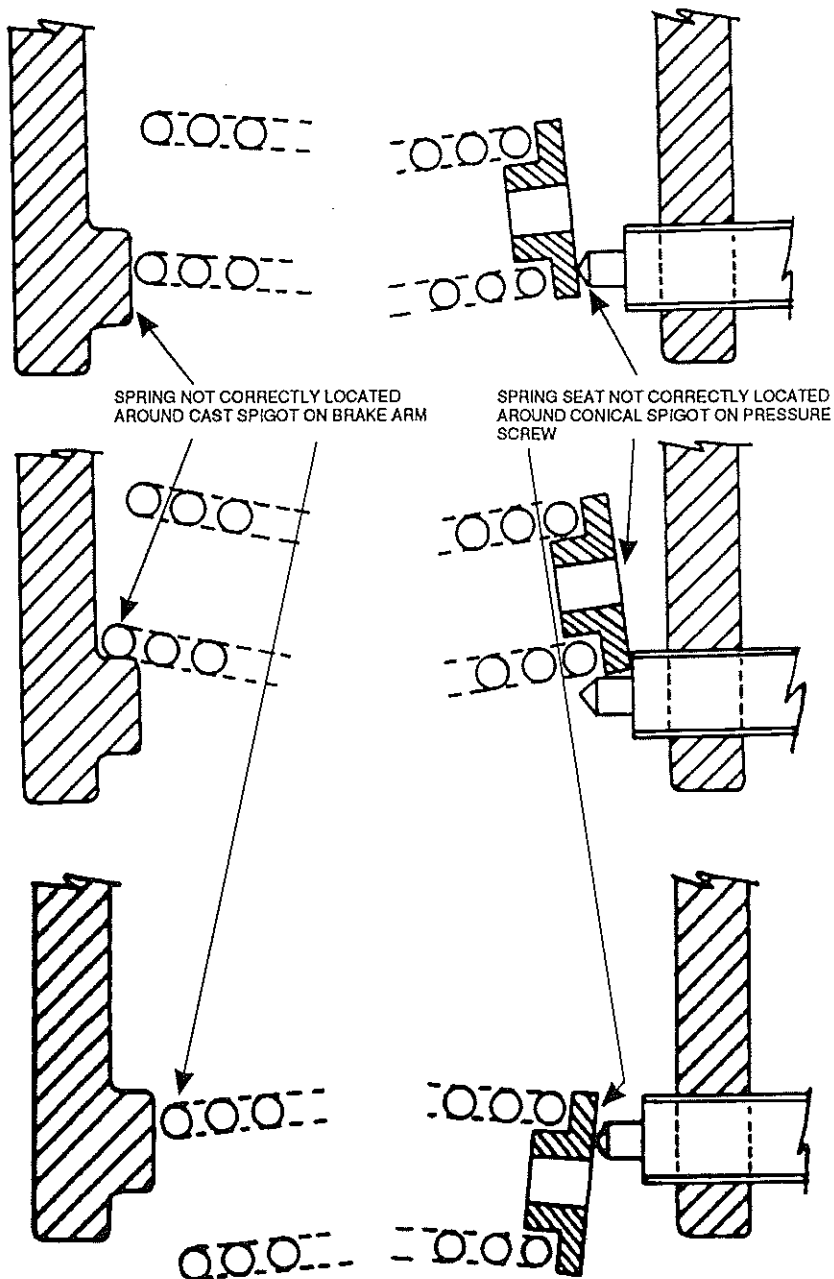

EXAMPLES OF POTENTIALLY HAZARDOUS ASSEMBLIES OF COMPRESSION SPRING

FIGURE 2 - PRESSURE SCREW ASSEMBLY

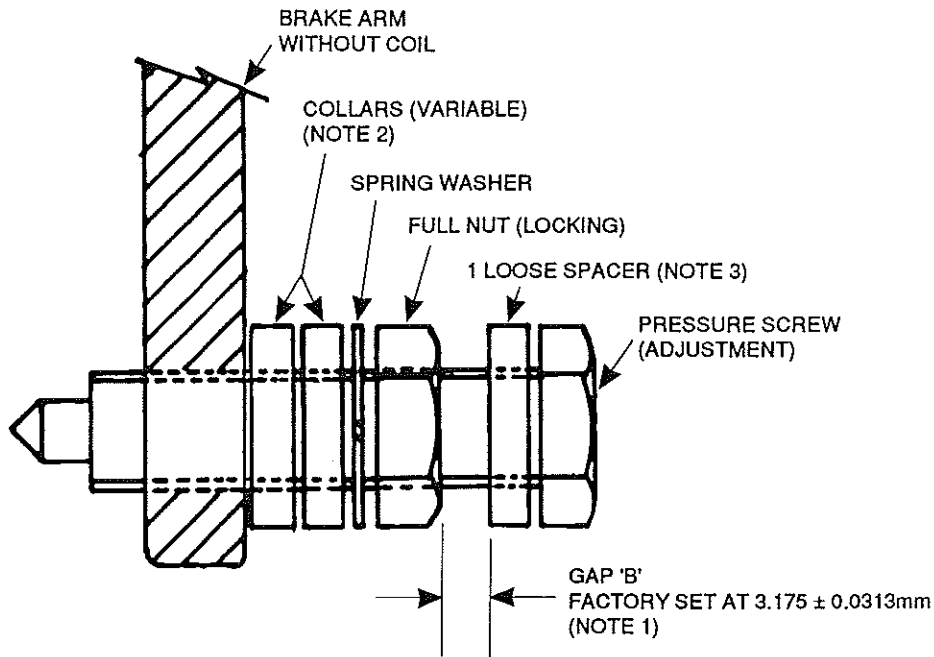

TYPICAL PRESSURE SCREW ASSEMBLY (ILLUSTRATION)

- NOTE 1** Gap 'B' is provided to compensate for wear of the friction surfaces. It is always factory set within the dimensions and tolerances detailed above.
- NOTE 2** The quantity and depth of collars fitted on each individual brake will vary. The collars are selected during the factory test to compensate for manufacturing tolerances. When Gap 'B' is set correctly the brake will produce its full rated torque providing the new linings are fully bedded onto the brake drum.
- NOTE 3** The loose spacer is provided to cover any uncut thread on the pressure screw which would otherwise prevent the pressure screw from being fully tightened.
- NOTE 4** The pressure screw should not be completely removed from the brake arm casting, in order to eliminate the possibility of misplacing collars and spacer etc.

SAFETY

Gap 'B' is sensitive to change. It may be reduced to zero as the brake linings wear but should not be increased beyond the permitted maximum tolerance as the available torque then quickly reduces until the brake becomes ineffective.

LIFT TECHNICAL BULLETIN L.130

ELECTROMAGNETIC BRAKES

ELECTROMAGNETIC BRAKE TYPES DC, DNC, N AND T

Warning of Potential Safety Hazard

When brakes have been dismantled for new installation or maintenance purposes, it has been discovered that it is possible to reassemble the compression spring and spring seat incorrectly as illustrated in Figure 1.

If this occurs and the compression spring or spring seat should then slip in service, even into their correct locations, it is possible that the brake may not then exert sufficient force to hold its static load or decelerate a moving load.

Action Required

When reassembling a brake, take the following precautions:

1. Inspect the pressure screws, compression spring and spring seat to ensure that they have been correctly assembled as illustrated in Figures 1 and 2.

Location of the compression spring on the cast spigot of the brake arm and the spring seat on the conical spigot of the pressure screw can be readily checked by temporarily releasing spring pressure, releasing the pressure screw and rotating the spring and spring seat on their pivot points.

On some brakes, already assembled onto the brake drum, access limitations may necessitate temporary removal of the brake base fixing screws to enable the complete brake assembly to be moved sideways, in order to carry out the inspection procedure. If the brake is dismantled in this way, the reassembly and adjustment procedures must be fully implemented before the brake is put into service.

2. If the technique of correct assembly is not clear, you are recommended to read the step by step details in the Installation and Maintenance Instructions.

The above instructions are available from our Market Services Department at Hounslow by quoting Publication Number II010.