

# National Association of Lift Makers

# NALM

33/34 Devonshire Street London W1N 1RF  
Director D M Fazakerley

telephone: 071-935 3013  
fax: 071-935 3321

To: All Members  
cc: The Quality and Technical Committee (1735)

18 October 1993

Dear Sir,

## **Hammond and Champness Ltd, G70 Overspeed Governor**

Due to a reported slight machining error on the above referenced overspeed governor rope clamping jaw, and although this does not appear to alter operational performance of the governor and its effectiveness to operate the safety gear, it is considered prudent that all existing clamping jaws be replaced.

For recognition purposes an illustration of the G70 overspeed governor is attached. Replacement jaw kits (part no 2.2041.21.01) containing fitting instructions are available from:

Hammond and Champness Ltd  
Albion Park, Armley Road  
Leeds, LS12 2EJ

Yours faithfully,



D M Fazakerley  
Director

# GOVERNOR G.70

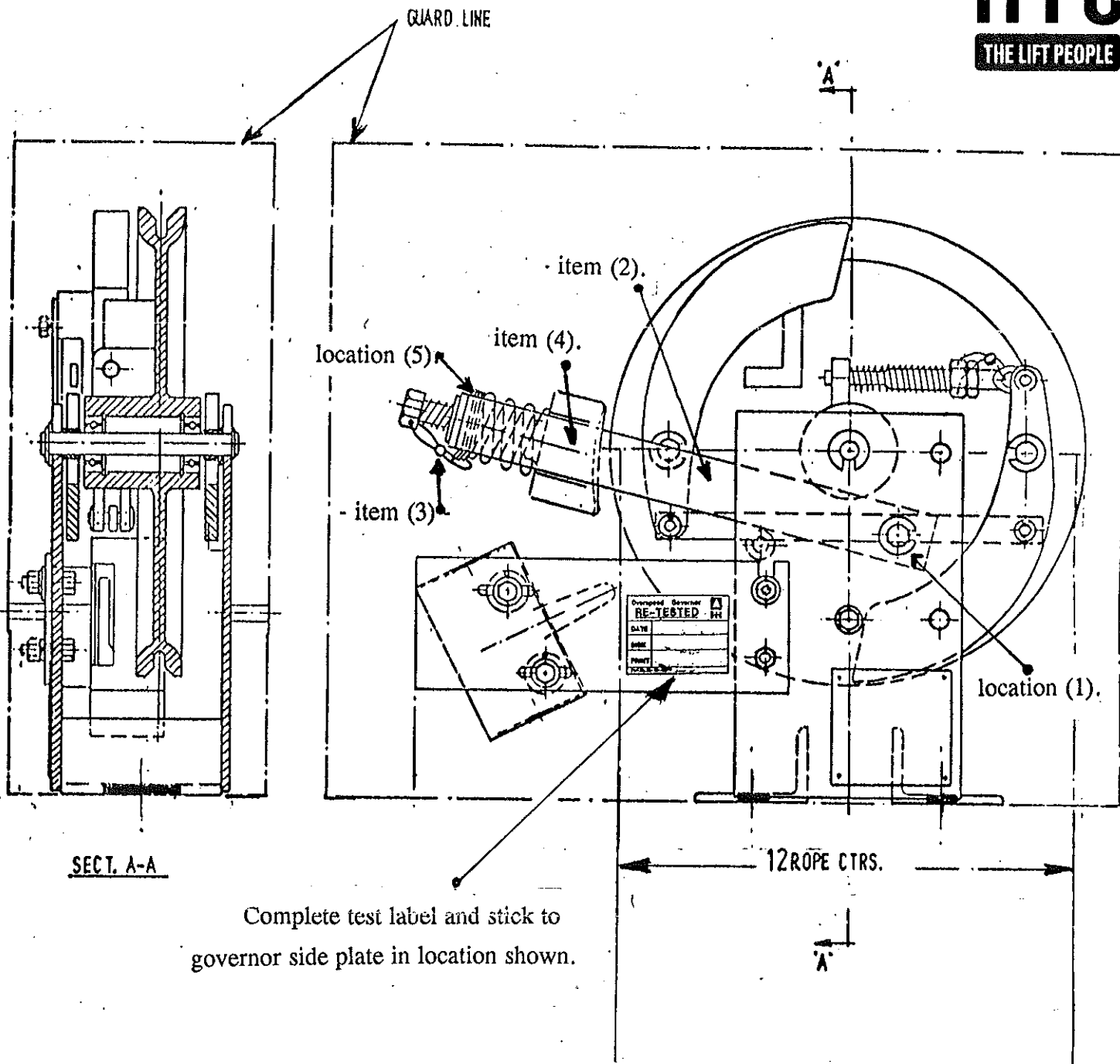
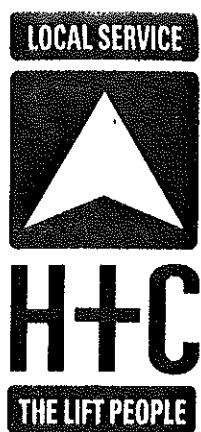

Complete test label and stick to governor side plate in location shown.

GOVERNOR NOT HANDED. AS DRAWN ONLY.

drawing No CEI/210.

**HAMMOND + CHAMPNESS LTD**  
GNOME HOUSE, 7 BLACKHORSE LANE,  
WALTHAMSTOW LONDON E17 6DT  
TEL: 081 527 5522 FAX: 081 531 9609