

Important Notice Minivator 2000 Stairlift

It has come to our attention that a product upgrade programme carried out on Minivator 2000 curved stairlifts manufactured between 1st January 2002 and 31st August 2004 may not have captured all units within the batch identified as requiring the upgrade.

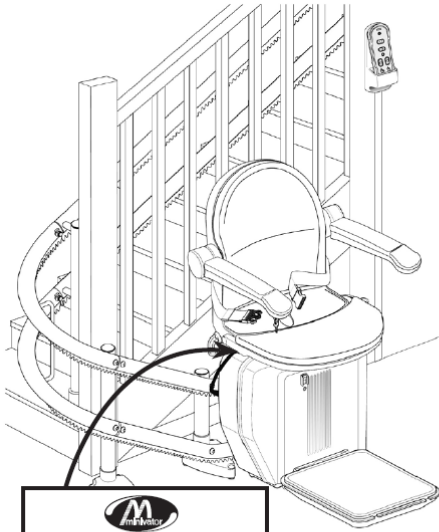

Whilst the chance of this is very slim, we invite owners of Minivator 2000 curved stairlifts, including reconditioned second hand units, to see if it is within the upgrade batch by checking the serial number which can be found on the label located on the top of the drive unit under the seat.

If your serial number starts with any of the number sequences listed below, please call our dedicated 24 hour registration service on 0800 090 1581 to register your stairlift with our team. We will then arrange to visit your stairlift to confirm the upgrade has been completed, or carry it out if required, free of charge.



01022, 02022, 03022, 04022, 05022, 06022, 07022,
08022, 09022, 10022, 11022, 12022, 01032, 02032,
03032, 04032, 05032, 06032, 07032, 08032, 09032,
10032, 11032, 12032, 01042, 02042, 03042, 04042,
05042, 06042, 07042, 08042



Notification of Product Recall Programme

Minivator 2000 Stairlift



Minivator conducted a safety critical upgrade programme in 2004 for Minivator 2000 stairlifts manufactured between 1st January 2002 and 31st August 2004.

If trade customers received product that fell within the recall they were sent a list of the units that Minivator wished to trace with a request that they provide details of where they were installed so they could be visited and upgraded.

Some of these businesses could not, or would not, provide these details which meant Minivator was unable to upgrade these units.

Despite their age, we believe some of these units may still be in use, either in their original location or because they have entered the second hand market.

Handicare, who purchased Minivator, wishes to locate these stairlifts so that we may conduct the upgrade and remove the risk to anyone using the stairlift.



ABOVE Minivator 2000 Upholstery variations.

BELOW Serial number Label



Important Notice Minivator 2000 Stairlift

It has come to our attention that a product upgrade programme carried out on Minivator 2000 curved stairlifts manufactured between 1st January 2002 and 31st August 2004 may not have captured all units within the batch identified as requiring the upgrade.

Whilst the chance of this is very slim, we invite owners of Minivator 2000 curved stairlifts, including reconditioned second hand units, to see if it is within the upgrade batch by checking the serial number which can be found on the label located on the top of the drive unit under the seat.

If your serial number starts with any of the number sequences listed below, please call our dedicated 24 hour registration service on 0800 090 1581 to register your stairlift with our team. We will then arrange to visit your stairlift to confirm the upgrade has been completed, or carry it out if required, free of charge.

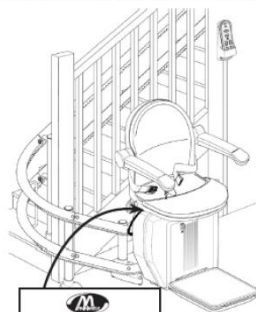

01022, 02022, 03022, 04022, 05022, 06022,
07022, 08022, 09022, 10022, 11022, 12022,
01032, 02032, 03032, 04032, 05032, 06032,
07032, 08032, 09032, 10032, 11032, 12032,
01042, 02042, 03042, 04042, 05042, 06042,
07042, 08042

We will be contacting mobility dealers throughout the country to ask them to look for these units when conducting service or maintenance visits.

We will also be running a national press advertising campaign (example opposite) to ask end users to check their units and contact us if they have a Stairlift that falls within the recall.



The advert will carry a contact number but you may be contacted by a customer.

Please refer them to freecall 0800 090 1581 to check the unit and register it with us if it fails within the upgrade batch.

On locating units requiring upgrade Handicare will take the necessary action at no cost to the customer.